

Air Combination (Filter + Regulator)

Features

- ▶ Safety steel bowl guard - Push in turn type
- ▶ Modular Mounting Type
- ▶ Manual drain push type
- ▶ Sinter Bronze Filter Element
- ▶ Suitable for Panel and Modular Mounting Type
- ▶ Diaphragm Operated
- ▶ Faster Response
- ▶ Maximum Flow Rate

Technical Specification

Model	JHFRC-13	JHFRC-14A	JHFRC-14B	JHFRC-15	JHFRC-17A	JHFRC-17B
Size	1/4"	1/4"	3/8"	1/2"	3/4"	1"
Opr. Pressure	10 Kg/cm ² (max.)					
Temperature	50 °C (max.)					
Seals	NBR					
Media	Compressed air					
Weight (Approx.)	0.220	0.300	0.300	0.560	1.080	1.080

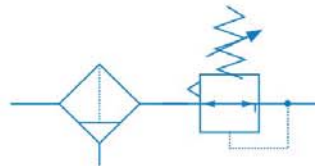

JHFRC - 13 (1/4")

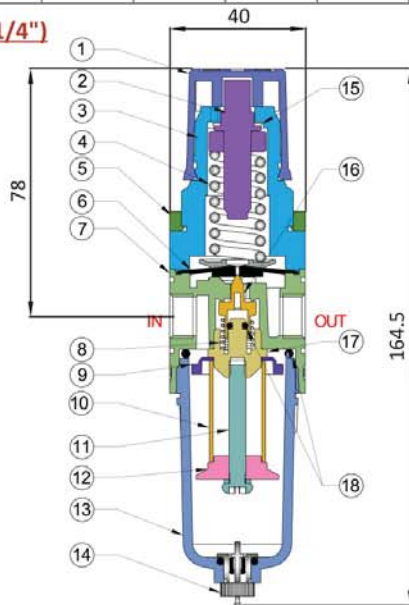

No.	Part Name	Material
1	Knob	Nylon
2	Adjusting Stud Key	Steel Plated
3	Bonnet	Nylon
4	Spring	Spring Steel
5	Penal Ring	Nylon
6	Diaphragm Assem.	NBR with Brass
7	Body	Aluminum Pressure Die Cast
8	Spring	S. S.
9	Deflector	Nylon
10	Filter Element	Sinter Bronze (20 Micron)
11	Screw	S. Steel
12	Baffle	Nylon
13	Bowl	Polycarbonate
14	Drain Cock	Brass
15	Adjusting Flat Ring	Polyacetal
16	Plunger NBR Mould	Brass
17	Plunger Guide	Zinc Cast
18	'O' Ring	NBR

JHFRC - 14A & 14B (1/4" & 3/8")

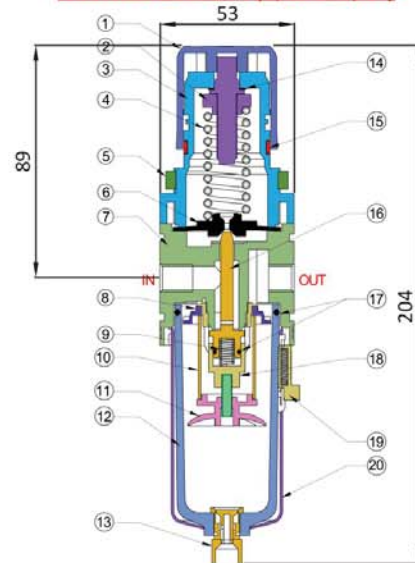

No.	Part Name	Material
1	Knob	Nylon
2	Adjusting Stud Key	Steel Plated
3	Bonnet	Nylon
4	Spring	Spring Steel
5	Penal Ring	Nylon
6	Diaphragm Assem.	NBR with Brass
7	Body	Aluminum Pressure Die Cast
8	Deflector	Nylon
9	Spring	S. Steel
10	Filter Element	Sinter Bronze (20 Micron)
11	Baffle	Nylon
12	Bowl	Polycarbonate
13	Drain Assembly	Brass
14	Adjusting Flat Ring	Polyacetal
15	Flat Ring	Polyacetal
16	Plunger	Brass with NBR Molded
17	'O' Ring	NBR
18	Plunger Guide	Zinc Cast
19	Lock	Nylon
20	Safety Guard	Sheet Metal

**Air Combination
(Filter + Regulator)**

JHFRC - 15 (1/2")

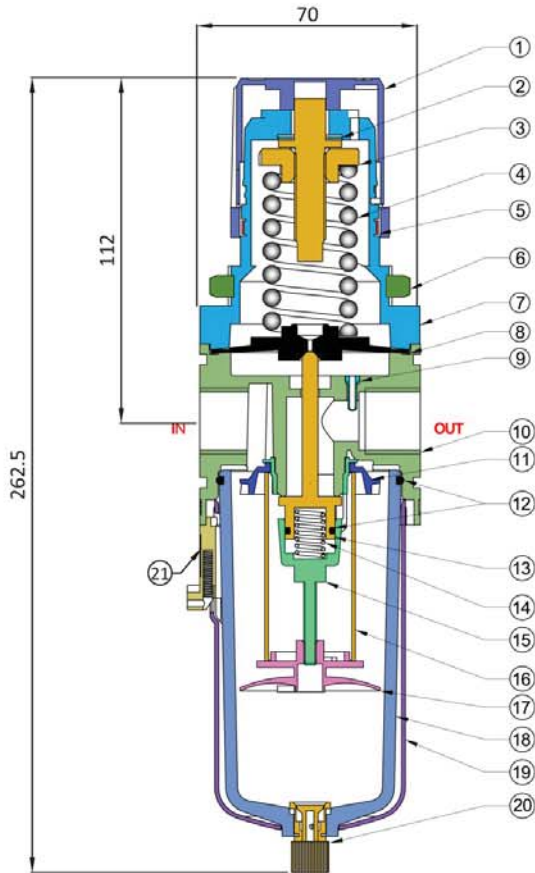

No.	Part Name	Material
1	Knob	Nylon
2	Adjusting Flat Ring	Polyacetal
3	Adjusting Stud Key	Steel Plated
4	Spring	Spring Steel
5	Flat Ring	Polyacetal
6	Penal Ring	Nylon
7	Bonnet	Aluminum Pressure Die Cast
8	Diaphragm Assem.	NBR with Brass
9	Vent Sleeve	Polyacetal
10	Body	Aluminum Pressure Die Cast
11	Deflector	Nylon
12	'O' Ring	NBR
13	Plunger NBR Mould	Brass
14	Spring	S. Steel
15	Guide	Polyacetal
16	Filter Element	Sinter Bronze (20 Micron)
17	Baffle	Nylon
18	Bowl	Polycarbonate
19	Safety Guard	Sheet Metal
20	Drain Assembly	Brass
21	Lock	Nylon

JHFRC - 17A & 17B (3/4" & 1")

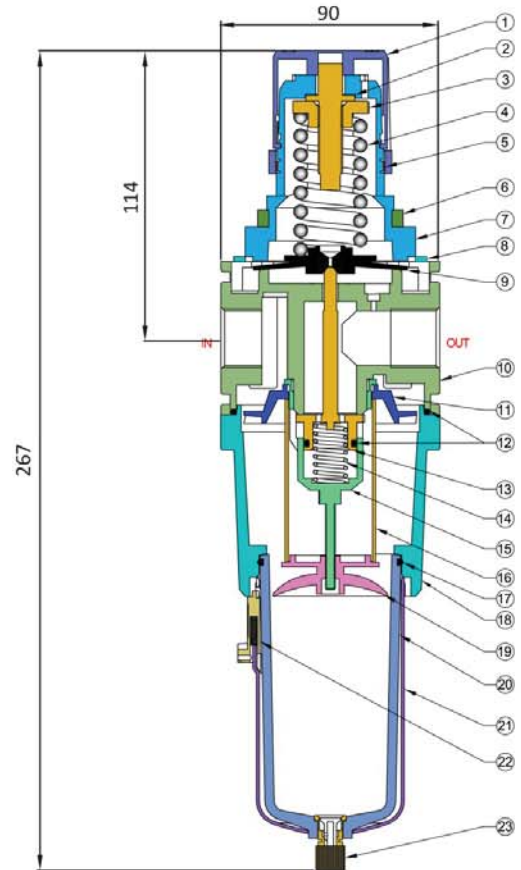

No.	Part Name	Material
1	Knob	Nylon
2	Adjusting Flat Ring	Polyacetal
3	Adjusting Stud Key	Steel Plated
4	Spring	Spring Steel
5	Flat Ring	Polyacetal
6	Penal Ring	Nylon
7	Bonnet	Aluminum Pressure Die Cast
8	Gasket	Nylon
9	Diaphragm Assem.	NBR with Brass
10	Body	Aluminum Pressure Die Cast
11	Deflector	Nylon
12	'O' Ring	NBR
13	Plunger with NBR Molded	Brass
14	Spring	S. Steel
15	Guide	Polyacetal
16	Filter Element	Sinter Bronze (20 Micron)
17	'O' Ring	NBR
18	Housing	Aluminum Pressure Die Cast
19	Baffle	Nylon
20	Bowl	Polycarbonate
21	Safety Guard	Sheet Metal
22	Lock	Polycarbonate
23	Drain Assembly	Brass